

1250W AC-DC Charger Specification

1250瓦AC-DC充电器规格书

QA1250A-29.2V30A

V1.0

2024/5/14

| XYM Signatures | | | | Customer Approval Signature | |
|----------------|---------|------|----------|-----------------------------|--|
| Prepared | Checked | | Approved | Marketing | |
| | ME | 研发经理 | | | |
| | | | | | |

Please return us one copy of the document with your approval signature.

请客户确认签字后回传我司此规格承认书。

Hefei Power Forever Electronic Technology Co.,Ltd.
合肥鑫宇铭源电子科技有限公司

A2-d-503, Building A2-D, Zone A, Jiahai Industrial Park, east of Xinbengbu Road, South of Meichunhu Road, Xinzhan District, HEFEI CITY

合肥市新站区新蚌埠路以东梅冲湖路以南合肥佳海工业城A区A2-幢A2-D-503号

TABLE OF CONTENTS/目录

| | | |
|----------|---|----------|
| 1 | GENERAL/产品概述 | 4 |
| 2 | ELECTRICAL PERFORMANCE/电气性能 | 5 |
| 2.1 | Input Characteristics/输入特性 | 5 |
| 2.2 | Input Voltage and Frequency/输入电压与频率 | 5 |
| 2.3 | Input Current /输入电流 | 5 |
| 2.4 | AC Line Inrush Current (25 °C Cold Start)/浪涌电流 (25 °C冷启动) | 5 |
| 2.5 | Power Factor/功率因数 | 5 |
| 2.6 | Efficiency/效率 | 5 |
| 2.7 | AC Line Brownout/输入欠压 | 5 |
| 3 | Output Characteristics/输出特性 | 6 |
| 3.1 | Output constant voltage point /输出恒压点 | 6 |
| 3.2 | Static Output Characteristics/静态输出特性 | 6 |
| 3.3 | Ripple & Noise/纹波与噪声 | 7 |
| 3.4 | Turn-on Delay Time/开机延迟时间 | 7 |
| 4 | Protection Circuits/保护电路 | 7 |
| 4.1 | Software Over Voltage Protection//软件过压保护 | 7 |
| 4.2 | Hardware Over Voltage Protection//硬件过压保护 | 7 |
| 4.3 | Short Circuit Protection/短路保护 | 7 |
| 4.4 | Under Voltage Protection/低电压保护 | 7 |
| 4.5 | Anti Reverse Polarity Protection/电池反接保护 | 7 |
| 4.6 | Over Temperature Protection/过温保护 | 8 |
| 4.7 | Timing protection/定时保护 | 8 |
| 5 | Derating Curve/降额曲线 | 8 |
| 6 | COMMUNICATION PROTOCOL/通信协议 | 8 |
| 7 | STATE INDICATOR/状态指示 | 8 |
| 8 | POWER CABLES /功率线 | 9 |
| 8.1 | Input () | 9 |
| 8.2 | Output(备注: 线材、插头阻燃等级V0) | 9 |
| 9 | ENVIRONMENTAL/环境适应性要求 | 9 |
| 9.1 | Operating Temperature and Relative Humidity/操作温度与湿度要求 | 9 |

| | | |
|-----------|--|-----------|
| 9.2 | <i>Storage Temperature and Relative Humidity/存储温度与湿度要求</i> | 9 |
| 9.3 | <i>Ingress Protection Grade/防护等级</i> | 9 |
| 9.4 | <i>MTBF/Life Time/平均无故障运行时间/产品寿命</i> | 9 |
| 9.5 | <i>Vibration/振动</i> | 10 |
| 10 | REGULATORY/符合标准 | 10 |
| 10.1 | <i>Agency Requirements/安规认证</i> | 10 |
| 10.1.1 | Meet EN60335 | 10 |
| 10.2 | <i>Electromagnetic Compatibility/电磁兼容</i> | 10 |
| 10.2.1 | EMI/EMC Requirements..... | 10 |
| 11 | MECHANICAL/机构特性 | 11 |
| 11.1 | <i>Dimension and Outline Drawing/尺寸与外观示意图</i> | 11 |
| 11.2 | <i>Lable / 标签</i> | 11 |
| 11.3 | <i>Representative Case Design/典型外观</i> | 12 |
| 12 | REVISION LOG/修改记录 | 12 |

1 GENERAL/产品概述

This specification describes the performance characteristics of a 1250W Constant current to Constant Voltage output power supply for a variety of applications including charging of Electric Vehicle (EV)

and battery systems contained within them.

The model features in:

High efficiency: 92% typical @230Vac, full load

High power factor: 0.96 typical. @ 230Vac, full load

With Lightning Protection & all-round protections (AC BROWN-OUT, DC UVP&OVP&SCP&RCP ,OTP)

With LED indicator

本规格书详细描述了一款1250W恒流恒压输出电源的具体规格。

该款产品的特性包括:

高效率: 230Vac满载时效率典型值为92%

高功率因数: 230Vac满载时典型值为0.96

带雷击保护, 输入欠压保护, 输出过欠压保护、短路保护、反接保护, 过温保护

带LED指示灯

Waterproof metal shell type/防水金属壳

Common metal shell type/普通金属壳

Others/其他

2 ELECTRICAL PERFORMANCE/电气性能

Unless noted, the characteristics are specified for room temperature, 230Vac input, and full load output. 如无其它说明, 以下数据为室温, 230Vac 输入。满载输出时的规格。

2.1 Input Characteristics/输入特性

2.2 Input Voltage and Frequency/输入电压与频率

Input voltage: 90Vac to 264Vac / single phase

输入电压范围: 从90Vac到264Vac/ 单相输入

| Input/输入 | Min. | Typ. | Max. |
|----------------------|-------|------------|--------|
| Input Voltage/输入电压 | 90Vac | 115/230Vac | 264Vac |
| Input Frequency/输入频率 | 47Hz | 50/60Hz | 63Hz |

When the range of input voltage is from 90Vac to 170Vac need derating power running , refer to the derating curve.

90V~170V ac 输入条件下, 需要降功率工作, 参照降额曲线。

2.3 Input Current /输入电流

12A max. @25°C 115Vac input & Full load/满载

8A max. @25°C 230Vac input & Full load/满载

2.4 AC Line Inrush Current (25°C Cold Start)/浪涌电流 (25°C冷启动)

No component shall be damaged and the input fuse shall not blow when the power supply is powered on @230Vac

在230Vac开机瞬间任何零件以及保险丝不得烧毁。

2.5 Power Factor/功率因数

| Items | Min./最小 | Typ./典型 | Test Condition/测试条件 |
|-------------------|---------|---------|-----------------------|
| Power Factor/功率因数 | 0.96 | 0.99 | 115Vac, Full Load//满载 |
| | 0.95 | 0.99 | 230Vac, Full Load//满载 |

2.6 Efficiency/效率

| Items | Min./最小 | Typ./典型 | Test Condition/测试条件 |
|---------------|---------|---------|------------------------------|
| Efficiency/效率 | 88% | 90% | 115Vac, 90% Full Load/ 90%满载 |
| | 89% | 92% | 230Vac, Full Load/满载 |

2.7 AC Line Brownout/输入欠压

The power supply shall not damage when the input falls below 90Vac.

在输入交流电压低于 90 Vac 情况下，电源不会损坏。

3 Output Characteristics/输出特性

3.1 Output constant voltage point /输出恒压点

Constant voltage output is $29.2 \pm 0.2V$. (Test condition : CC model 0.3A)

恒压点 $29.2 \pm 0.2V$. (测试条件: CC 带载 0.3A)

3.2 Static Output Characteristics/静态输出特性

| Items | Min. | Typ. | Max. |
|--|---------------|-------|-------|
| Output Current limit range/输出电流范围 | 28.5A | 30A | 31.5A |
| Output Current limit range after derating power/降功率后输出电流范围 | 25A | 26.4A | 27.7A |
| Efficient charge output voltage /高效充电输出电压 | $20.4 \pm 1V$ | | 28.3V |
| Maximum output voltage /最高输出电压 | 29V | 29.2V | 29.4V |
| Output Power/输出功率 | | | 1250W |

Charging Curve/充电曲线: (典型值 AC 230V)

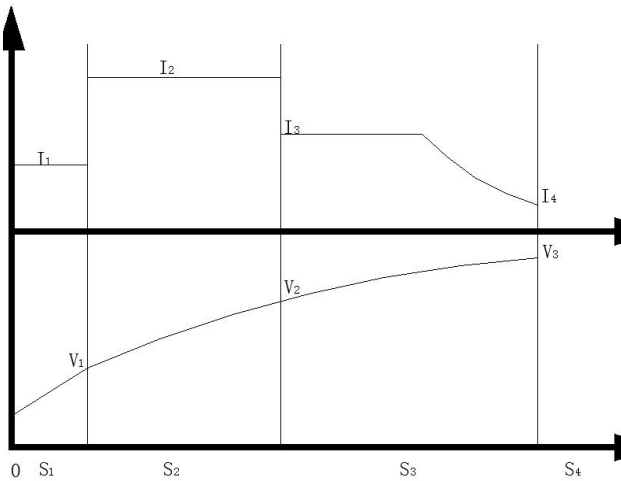

| $S1 \leq 2H$ | $S2 \leq 10H$ | $S3 \leq 4H$ | $S4$ |
|----------------------------|---------------|----------------------------|------|
| $V_0=14.7V$ $V_1=20.4V$ | $V_2=28.3V$ | $V_3=29.2V$ | 充满 |
| $I_1=3A$ | $I_2=30A$ | $I_3=10A$ $I_4 \leq 3A$ | 0A |
| 红灯快闪 | 红灯慢闪 | 绿灯慢闪 | 绿灯亮 |

3.3 Ripple & Noise/纹波与噪声

Current Ripple: $\pm 15\%$ I_o max., with typical Battery at 25°C , @ 220Vac input, measured at 20MHz bandwidth.

电流纹波: 220Vac 输入, 在 25°C , 典型电池负载, 使用 20MHz 带宽测量时, 不超过 $\pm 15\%$ I_o 。

3.4 Turn-on Delay Time/开机延迟时间

5.0s max. @ Full Load/满载时最大 5s。

4 Protection Circuits/保护电路

4.1 Input voltage abnormal protection//输入电压异常保护

When the power supply exceeds the input voltage range, the charger does not work. The power supply can be restored after it is normal.

当电源超出输入电压范围是充电器不工作, 电源正常后可自行恢复。

4.2 Hardware Over Voltage Protection//硬件过压保护

When the output voltage exceeds 30V, the charger triggers the hardware overvoltage protection. In case of failure, the charger should enter the lock protection mode. When the fault is rectified, the charger automatically recovers.

当输出电压超过30V时, 充电器触发硬件过压保护。故障时充电器应进入锁死保护模式。当故障排除后, 充电器自动恢复。

4.3 Short Circuit Protection/短路保护

When the output short-circuit occurs, the charger is protected and the power supply can be restored. After the fault is rectified, it automatically resumes work

当输出发生短路时,充电器保护, 电源可恢复。故障排除后,自动恢复工作

4.4 Under Voltage Protection/低电压保护

When the output voltage of the charger is less than 14.7V, it enters the low-voltage protection mode. When the fault is removed, the charger can automatically recover

当充电器输出电压小于14.7V, 进入低压保护模式, 当故障排除后,充电器可自动恢复

4.5 Anti Reverse Polarity Protection/电池反接保护

When the battery polarity is reversed, the charger is protected and automatically resumes work after the fault is removed

当电池极性接反时, 充电器保护, 故障排除后, 自动恢复工作

4.6 Over Temperature Protection/过温保护

When the internal temperature of the charger exceeds 45° C, the charger output derates to 70%

After the temperature returns, restart the charger to return to normal

充电器内部温度超过45°C时，充电器输出降额至70%温度恢复后，重新启动充电器恢复正常。

4.7 Timing protection/定时保护

When the charging time exceeds 14 hours, the charger should stop working. Automatic recovery

当充电时间超过 14小时，充电器应停止工作。自动恢复

5 De rating Curve/降额曲线

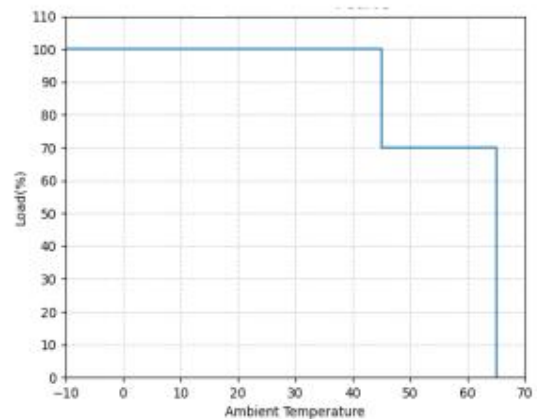
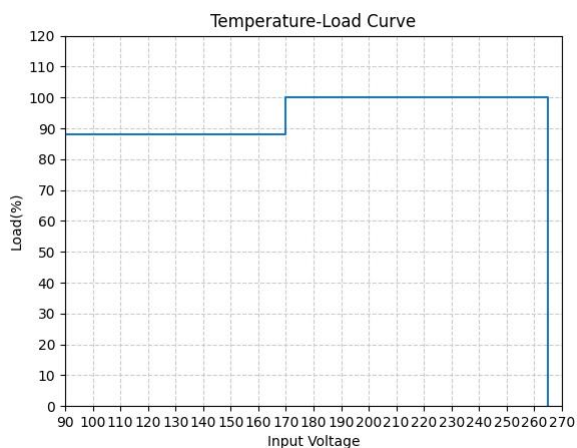

1. 当输入电压低于170Vac时，电源输出电流降到 88%。
2. 当温度升到 45±5°C时，电源输出电流降到 70%。
3. 当温度超过 65±5°C时，电源 OTP 保护。

6 COMMUNICATION PROTOCOL/通信协议

NG/无

7 STATE INDICATOR/状态指示

- 1) Flashing red and green/红绿交替闪: Charging waiting /充电等待
- 2) Blinking red lamp/红灯闪: Fast charge /快充
- 3) Green flash/绿灯闪: Constant voltage and current limiting/恒压限流
- 4) GREEN/绿灯: Charge complete /充电完成
- 5) Input voltage fault/输入电压故障: Red green Red green Red stop cycle/红绿红绿红停 循环
- 6) Overvoltage fault/过压故障: Red green Red green Red stop cycle/ 红绿红停停停 循环
- 7) Overtemperature fault/过温故障: Green and red stop-stop cycle/绿红停停停停 循环
- 8) Flashing red and green/红绿交替闪: Reverse short circuit/反接短路
- 9) Flashing red and green/红绿交替闪: low voltage protection/低电压保

8 POWER CABLES /功率线

8.1 Input ()

8.2 Output (备注：线材、插头阻燃等级V0)

输入线：3*1mm²*1.2米。

Input line: 3*1mm²* 1.2m

输出线：2*2.5mm²*1.1米

Output line: 2*2.5mm²*1.1 m

注：仅供参考，最终以实物客户要求为准。（可以安客户要求订制接口端子）

9 ENVIRONMENTAL/环境适应性要求

The power supply shall operate normally, and sustain no damage as a result of the environmental conditions listed in this section.

电源在本节所描述的环境下可以正常工作且不损坏。

9.1 Operating Temperature and Relative Humidity/操作温度与湿度要求

-20°C to +45°C.

20% RH to 85% RH.

Note:

The temperature rise when the charger is under operation shall less than 30 °C(ΔT)

/充电器工作时机壳表面温升需控制在30度以内。

9.2 Storage Temperature and Relative Humidity/存储温度与湿度要求

-25°C to +85°C.

5% RH to 95%RH.

9.3 Ingress Protection Grade/防护等级

NG/无

9.4 MTBF/Life Time/平均无故障运行时间/产品寿命

The MTBF shall beat least 100,000 hours at 25°C, Full load and nominal input condition.

平均无故障运行时间：至少100,000小时，25 °C环境及额定输入与满载条件下。

The life time shall beat least 15,000 hours at 25 °C ambient temperature, Full load and nominal input condition.

产品寿命：至少15,000小时，25 °C环境温度及额定输入与满载条件下。

9.5 Vibration/振动

10 to 500Hz sweep at a constant acceleration of 2.0G (Breadth: 3.5mm), 10minutes/1cycle. X, Y, Z three vertical coordinates vibrate axially for 2 hours.

扫描频率: 10 to 500Hz, 加速度: 2.0G(位移: 3.5mm), 10分钟/1周期.X, Y, Z 三垂直坐标轴向各振动 2 小时

10 REGULATORY/符合标准

10.1 Agency Requirements/安规认证

11 MECHANICAL/机构特性

11.1 Dimension and Outline Drawing/尺寸与外观示意图

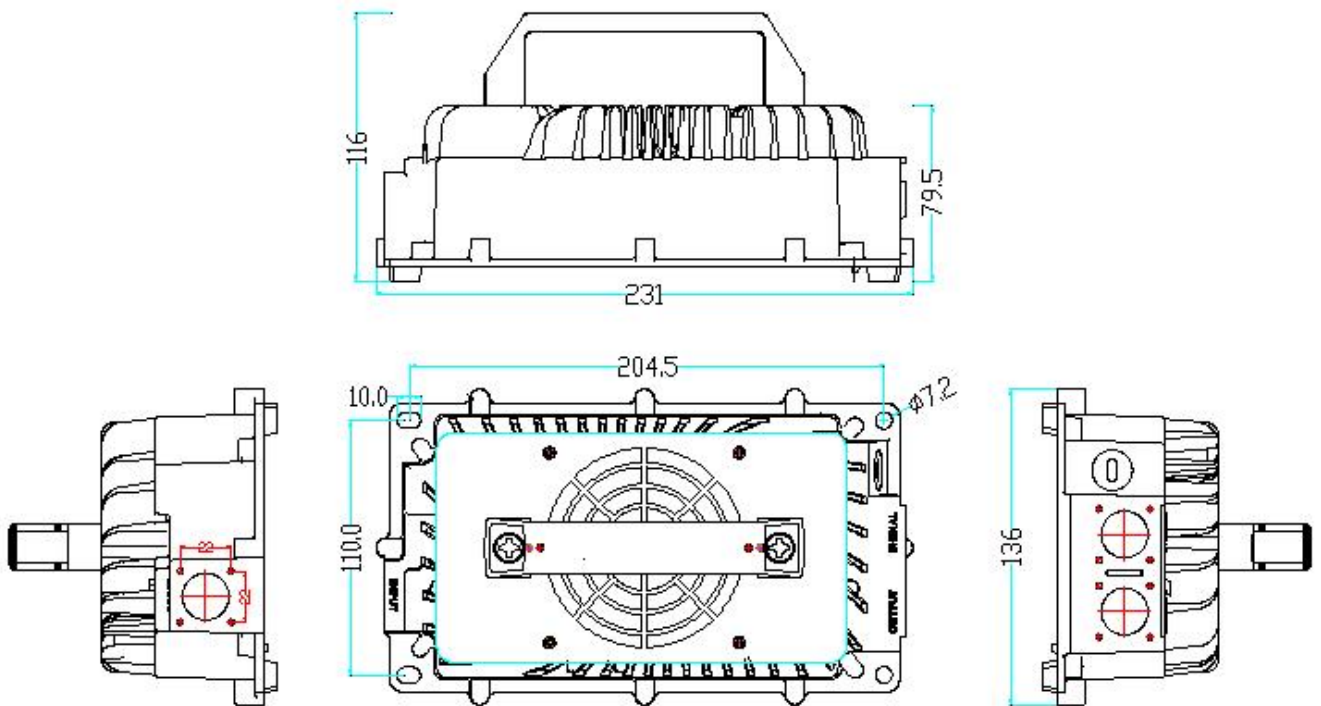

11.2 Label /标签

11.3 Representative Case Design/典型外观



12 REVISION LOG/修改记录

This section contains the release history of this document:

本部分包含本文档的修改历史记录:

